

Fiber Optics Distribution Box

Serie 31

Overview

Distribution box is used as a termination point for the feeder cable to connect with drop cable in FTTx communication network system. The fiber splicing, splitting, distribution can be done in this box, and meanwhile it provides solid protection and management for the FTTx network building.

Features

- Total enclosed structure.
- Material: PC+ABS
- Wet-proof, water-proof, dust-proof, anti-aging
- Protection level up to IP65.
- Clamping for feeder cable and drop cable, fiber splicing, fixation, storage, distribution all in one.
- Suitable for SC and LC duplex adapter and pigtail
- Easy to operate
- Suitable for both outdoor and indoor use
- Protects and manages cable effectively
- Secured with anti-theft locking mechanism
- Standard size, light weight

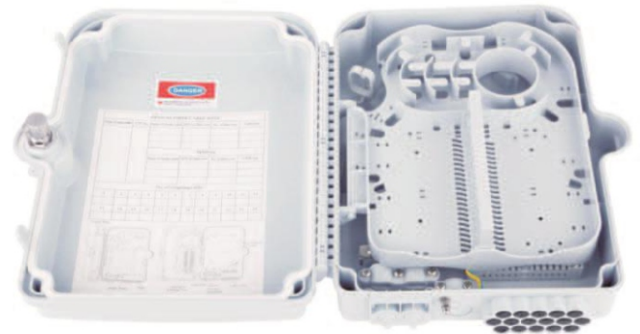
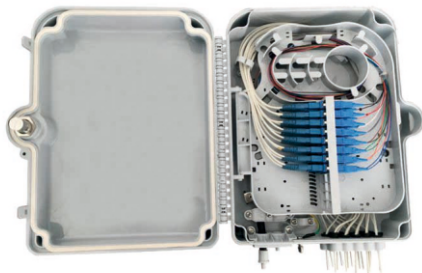

Dimensions and Capability

Dimensions (H*W*D)	317mm*237mm*101mm
Adapter Capacity	SC 16 PCs
Number of Cable Entrance/Exit	3 / 16
Weight	1 KG
Optional Accessories	Adapters, Pigtails, Heat Shrink Tubes, Splitters, Splice Tray
Insertion loss	≤0.2dB
UPC return loss	≥50dB
APC return loss	≥60dB
Life of insertion and extraction	≥1000 times
Insulation	The ground device is insulated with the Distribution box, IR ≥1000mΩ/500V(direct current)
Withstand Voltage	Between the grounding device and the box body, the withstand voltage is over 3000V/Min, no breakdown and flashover. U≥3000V(Direct current)

Operation Conditions

Temperature	-40°C -- +85°C
Humidity	≤ 85% (+30°C)
Air Pressure	70kPa – 106kPa

Shipping Information

Package Contents	Distribution box, 1 unit; Keys for lock, 1keys Wall mount installation accessories, 1 set
Package Dimensions(W*H*D)	380mm*300mm*160mm
Material	Carton box
Weight	1.5 KG
Lead Time	10-15 working days normally

Dimensions

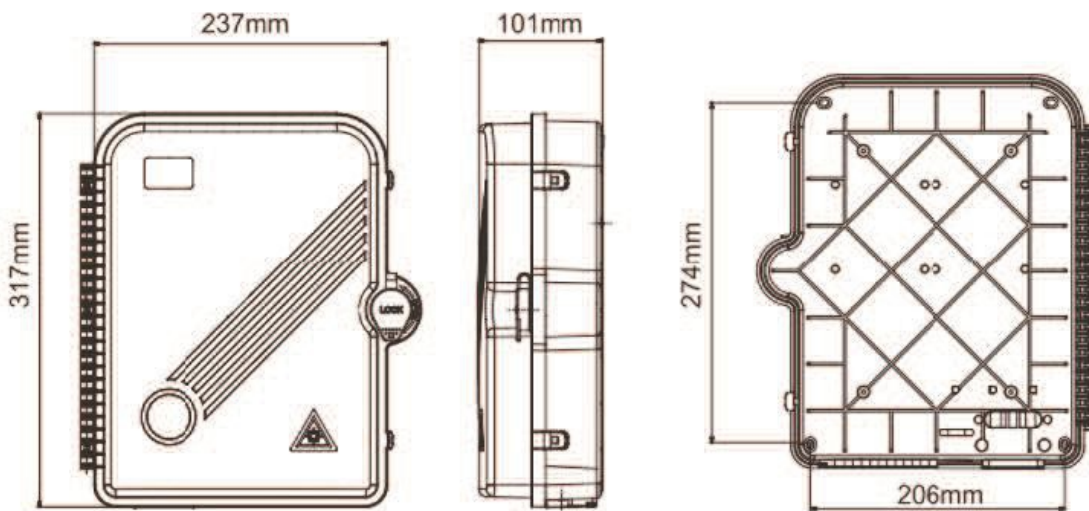

Installation

